

**FFDERA • ECM Motor • Room Side Replaceable Filter & Motor • Forward Inclined Fan**

### General Description

- Titus Fan Filter Diffusers provide constant unidirectional airflow to occupied space
- FFDERA offers high performance, low energy usage & low noise levels for use in cleanroom applications
- Low profile design is great for applications with limited ceiling plenum space
- Walkable plenum (excluding pre-filter), rated at 250 lbs
- EC motor with universal control card
- Forward curved centrifugal fan
- Snap-in prefilter allows for easy replacement and maintenance
- Tested to IEST recommended standards
- UL 507 Listed with standard UL 900 filters

## HEPA Filter and Motor Replacement Detail

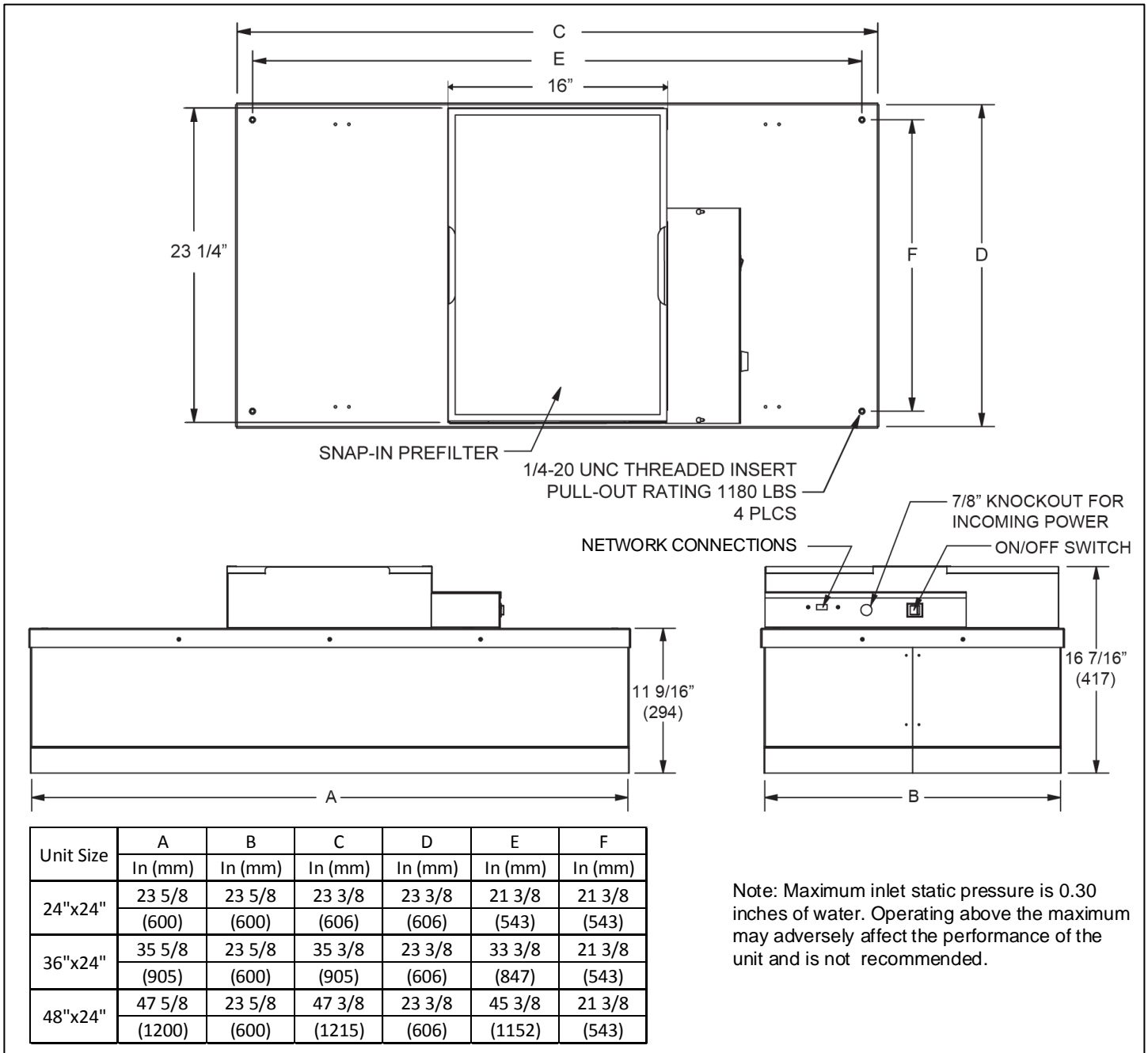
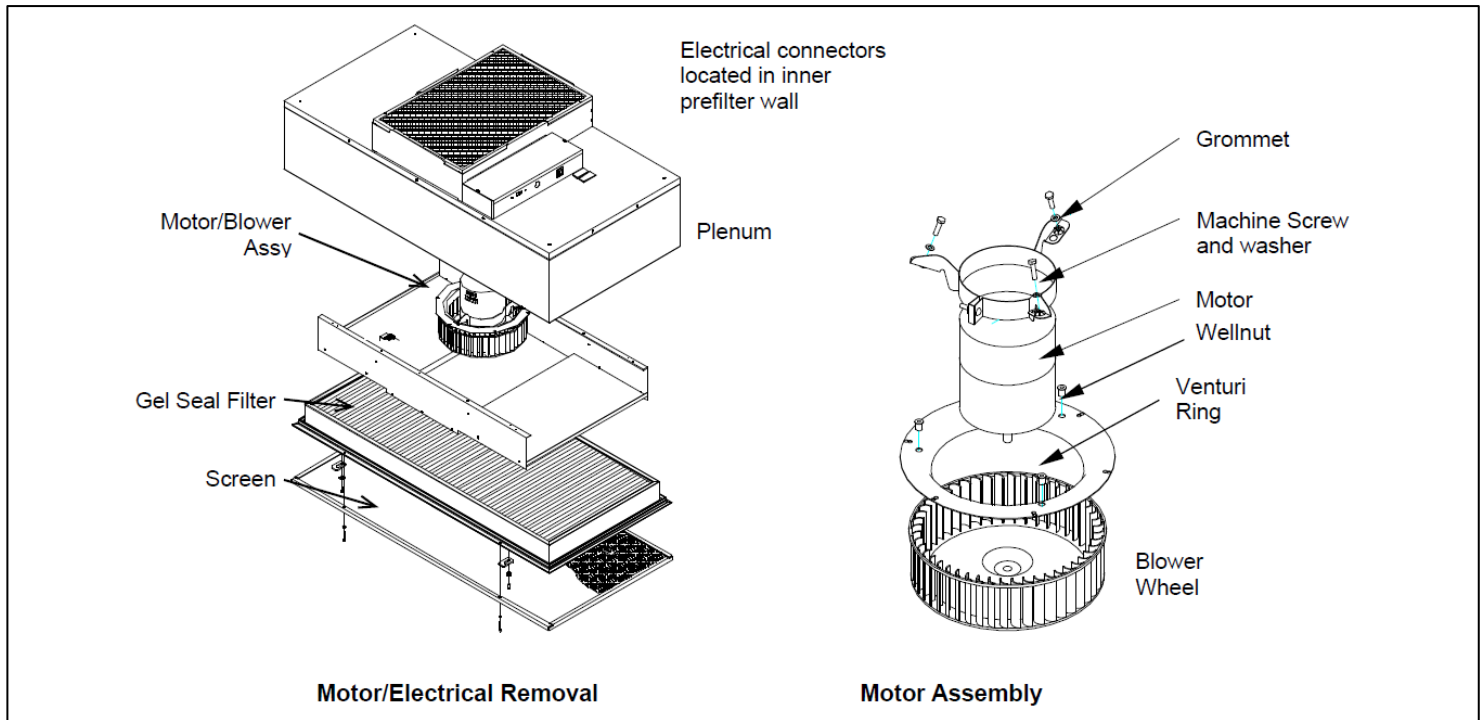

## Basic Unit Configuration

Check  if provided.

### Module Size

- 24" x 24"
- 36" x 24"
- 48" x 24"

### Finish

- #04 Mill Finish
- #26 White

### Control Type

- Universal Control Card
  - Constant CFM (Standard)
  - Low Air Flow / Constant Torque
  - Constant Speed
- Remote Mounted VCU Controller
- Infrared Speed Controller\*
  - \*Requires RCFF remote control to adjust unit airflow

### Duct Collar

- None
- 10" Inlet (Shipped Loose)
- 12" Inlet (Shipped Loose)

### Motor Type

- 115V/ 60 Hz/ 1 Phase ; FLA = 5.0A
- 230V/ 50/60 Hz/ 1 Phase ; FLA = 3.5A (CE Certified)
- 208-240V/ 50/60 Hz/ 1 Phase ; FLA = 3.5A
- 277V/ 60 Hz/ 1 Phase ; FLA = 2.0A

### Filter Type

- HEPA (99.99% @ 0.3 micron)
- ULPA (99.9995% @ 0.12 micron)

### Unit Construction

- Aluminum Face & Plenum
- Stainless Steel Face / Aluminum Plenum
- Stainless Steel Face & Plenum

## Accessories (Optional)

Check  if provided.

- Airflow Indicator Light (GREEN)
- Filter Load Indicator (RED)
- Continuous Filter Monitoring (0-10 V signal)
- Surface Mount Adapter
- Insulation
- Filter Ships Loose

This submittal is meant to demonstrate general dimensions of this product. The drawings are not meant to detail every aspect of the product. Drawings are not to scale.

Titus reserves the right to make changes without written notice.

All rights reserved. No part of this work may be reproduced or transmitted in any form or by any means, electronic or mechanical, including photocopying and recording, or by any information storage retrieval system without permission in writing from Air Distribution Technologies.

Challenge/Concentration Port Detail

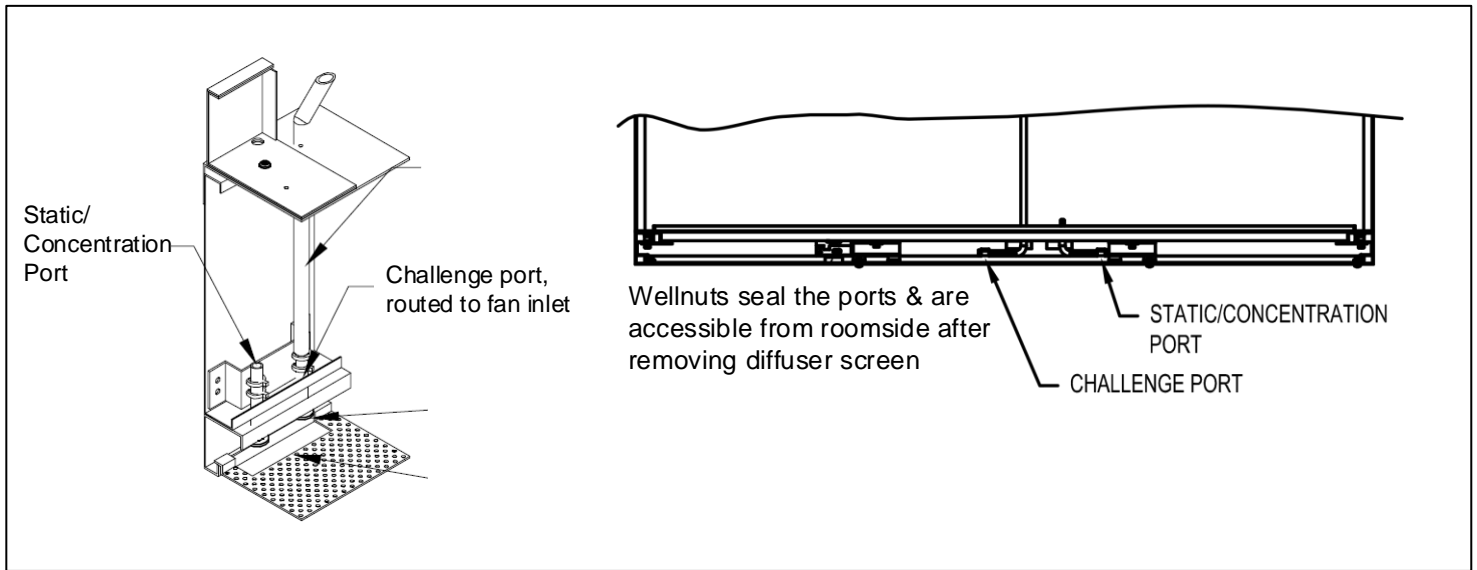

Inlet Adapter Accessory Detail

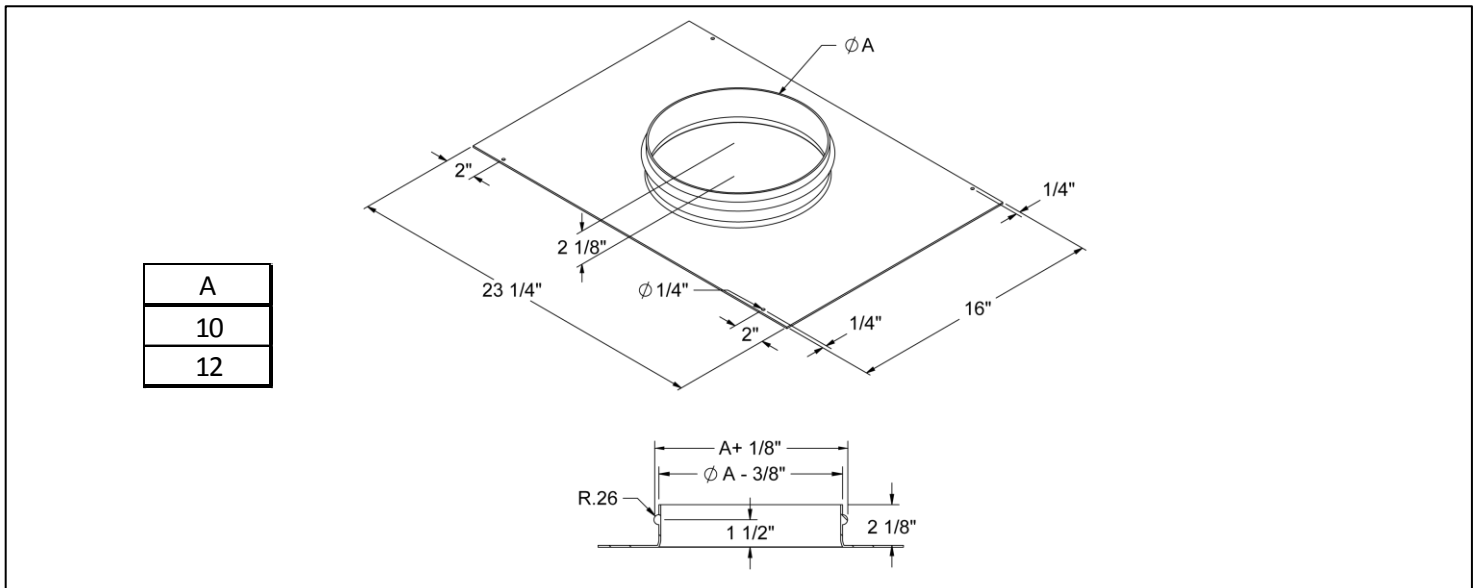

Surface Mount Adapter Accessory Detail

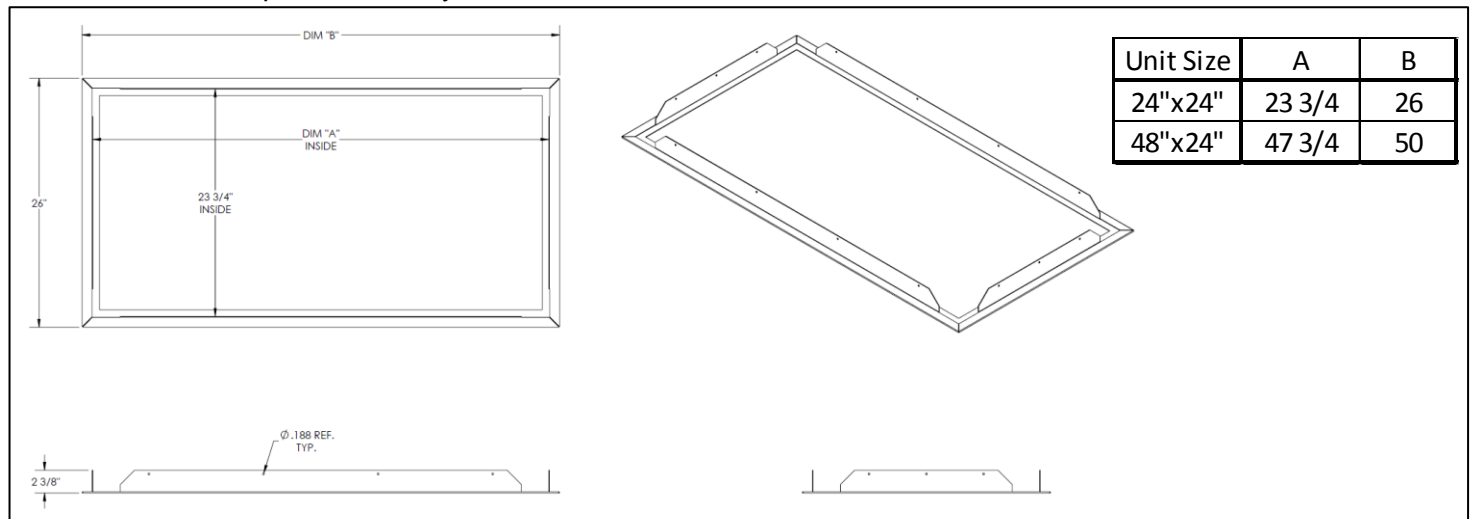

This submittal is meant to demonstrate general dimensions of this product. The drawings are not meant to detail every aspect of the product. Drawings are not to scale.

Titus reserves the right to make changes without written notice.

All rights reserved. No part of this work may be reproduced or transmitted in any form or by any means, electronic or mechanical, including photocopying and recording, or by any information storage retrieval system without permission in writing from Air Distribution Technologies.